

**Library Telescope
Program
Sponsored by
Central Arkansas
Astronomical Society
(CAAS)**

***Orion StarBlast 4.5"
Telescope***

INSTRUCTION MANUAL



WARNING: Never look directly at the Sun through your telescope or its finder scope — even for an instant — as permanent eye damage could result. Do not point the telescope at the Sun, as parts will melt! Children should use this telescope only with adult supervision.

INTRODUCTION

The Central Arkansas Library System Library Telescope Project (LTP) is supported by the Central Arkansas Astronomical Society (CAAS), which provides training for library staff, maintains the instruments and supports a dedicated website where more information about what to view with your LTP scope can be found at: <http://ltp.caasastro.org>

CAAS also holds public sky watches, demonstrations, presentations, and discussions, all free of charge. Monthly club meetings, held at the River Ridge Observatory each month, are also open to the public. For more information about the society and its activities visit: <http://www.caasastro.org/> where you can find a calendar of events, subscribe to a free event newsletter, and find links to many other astronomy-related sites. If you have questions or suggestions related to the LTP please email us at ltp_info@caasastro.org. If you have questions about the society e-mail us at info@caasastro.org.

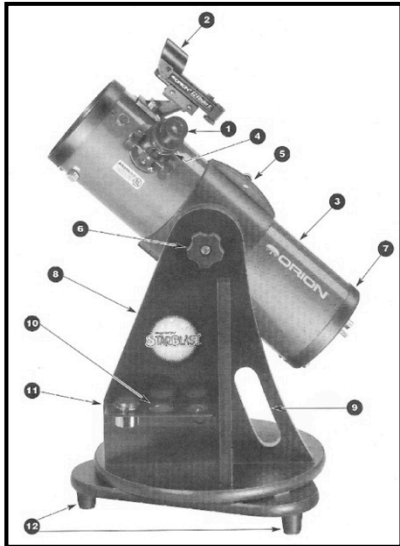

Telescope Parts

- 1) Eyepiece (Zoom 8 to 24 mm)
- 2) EZ Finder with AA battery box
- 3) Telescope tube
- 4) Focuser
- 5) Tube Clamp
- 6) Altitude Clamp
- 7) Mirror Assembly
- 8) Support
- 9) Handle
- 10) Eyepiece rack (removed)

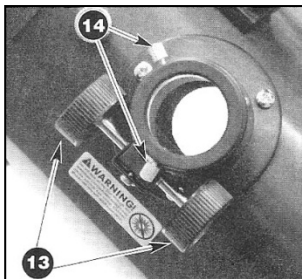

Focuser Details

- 13) Focus wheels
- 14) Eyepiece securing screws (replaced with hex screws)

EZ Finder Details

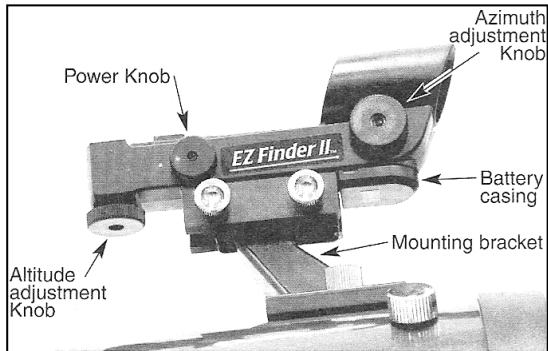

Transporting the Telescope

The easiest way to carry the scope is to place your forearm under the telescope tube when it is in a level position, and lift, holding the upright support against your side. When in a car, simply place the scope on a seat and use a seatbelt to secure it. The lap belt goes across the base, and the chest belt should cross the tube.

Care and Maintenance

Regarding cleaning the lenses or mirrors: Don't. Let the Librarian know if they seem dirty. Eye-pieces, however, can get dirty fairly quickly, particularly when poked with fingers. Please don't poke them as it's very easy to scratch the coatings. However, in case of minor smudges you might try using the LensPen. First, brush away any dust. Give the cap a quarter twist to replenish the compound on the cleaning tip inside, then uncover the tip and use it to clean the eyepiece. Be sure to store the telescope with the dust caps on.



Aligning the Mirrors: Again, please don't. If it seems that the telescope is in need of adjustment, please tell the Librarian.

Fog on the mirrors and eyepieces: One of the odd things that happens when star-gazing is that dew forms on pretty much everything (and everyone). The big mirror is tucked safely down at the bottom of the telescope, and so it does not get much dew on it. Eyepieces, however, often have dew form on them, making them useless until they warm up and dry out. If the eyepiece fogs up, wrap your hands around it for a few moments. As it warms up, the fog should disappear. Please don't wipe the lens with a tissue or cloth as it has special coatings on it that could be damaged if you do. Please ask people to not touch the lens... ever.

The Eyepiece chart on the telescope shows what magnification you will have for each setting of the Zoom Eye piece. The "True Field" describes the width of the image in the eyepiece. A full Moon is 30 minutes of a degree (or $\frac{1}{2}$ of a degree) wide, so you could fit about 4 full Moons in the field of view when using the 8mm setting. Change the Zoom setting until your target fits the eyepiece the way you like. You will have to tweak the focus.

Getting Started

Please read the instructions and practice with the telescope inside before you take it out in the dark. The image will be much better if you let the telescope cool down to air temperature before you start observing.

This is a “Push-to” telescope. Once you find what you are looking for, you can either watch the object move through your “field of view” (what you see through the eye piece) and then reposition the telescope, or keep pushing the scope to hold the object in the center of the eyepiece. Objects appear to move across the field of view faster at higher magnifications. This is because the field of view becomes narrower.

Like many reflector telescopes, the image in the eyepiece is upside-down.

When looking at star charts you will have to keep this in mind. The Moon map on this telescope is “flipped” so it matches what you see in the eyepiece.

Do You Wear Eyeglasses? If so, you will probably be able to observe with your glasses off by just refocusing the telescope to your unaided vision. If your eyes are astigmatic, images will probably appear best with glasses on. This is because a telescope’s focuser can accommodate for nearsightedness or farsightedness, but not astigmatism.

This is important enough to say again:

WARNING: Never look directly at the Sun through your telescope or its finder scope — even for an instant - as permanent eye damage could result. This is one of the few really bad things you can do to yourself twice. Young children should use this telescope only with adult supervision.

Focusing the Telescope: Try out the telescope during the day when you can see what you're doing. Remove the dust caps from the eyepiece and telescope tube.

The “power” of a given telescope depends upon the eyepiece you use. This scope has a Zoom eyepiece. Always start by using the telescopes' lowest-power (turn the body of the Zoom so the pointer is at “24”) to locate and center an object. Low magnification shows a larger area of sky in the eyepiece, making finding and centering an object much easier.

With the eyepiece adjusted for low power (24 mm), aim the telescope in the general direction of an object at least 1/4-mile away. Slowly rotate the focus wheels until the object comes into sharp focus. Go a little bit beyond sharp focus until the image starts to blur again, then reverse the rotation of the knob, just to make sure you've hit the exact focus point. When focusing on stars, bring them to as small a point as possible.

Many “deep-sky” objects are big, but dim. Low magnification will be better for them. Once you've centered an object in the eyepiece, you can switch to a higher magnification by twisting the Zooms' barrel towards the “8”. This is recommended for small and bright objects, like planets and double stars. The Moon also takes higher magnifications well. You may have to refocus a little after changing power.

If you find that it's awkward to put your eye up to the eyepiece, you can rotate the telescope tube by loosening the knob on the tube clamp and moving the telescope tube until the focuser is in a convenient position. Be sure to tighten it again!

You may find that the telescope tube is either too hard to move or does not stay in place. Use the altitude adjustment tension knob (it holds the telescope to the upright part of the base) to find the right level of tension.

Operating the EZ Finder

A “finder scope” helps you point the scope, rather like a rifle sight. The **EZ Finder** works by projecting a tiny red dot onto a screen mounted in the front of the unit, so that when you look through the screen, the red dot will appear to float in space. Turn the power knob clockwise until you hear a “click” indicating that power is on. With your eye positioned near the rear of the telescope, look through the EZ Finder with both eyes open to see the red dot. The intensity of the dot can be adjusted by turning the power knob. Use the dimmest possible setting that allows you to see the dot without difficulty. When the EZ Finder is properly aligned with the telescope, an object that is centered on the EZ Finder's red dot should also appear in the center of the telescope's eyepiece. Checking the alignment of the EZ Finder is easiest during daylight. Aim the telescope at a distant object, such as the top of a telephone pole or chimney and center it in the telescope's eyepiece. Now, turn the EZ Finder on and look through it. The object should appear near or under

the red dot. **If not:** Without moving the telescope, use the EZ Finder's left/right (azimuth) and up/down (altitude) adjustment knobs to position the red dot on the object in the eyepiece. If the red dot is centered on the object in the eyepiece, you're done!

The finder scope has a battery pack attached to the telescope. To change batteries, just slide the cover off the pack, and replace the two AA (or AAA) batteries. At the end of your observing session, be sure to turn the power knob counterclockwise until it clicks off.

What to Expect

Depending upon what is in the sky; Planets will look small, but you might be able to see cloud bands on Jupiter, some of its moons and the rings of Saturn. Craters on the Moon will be clear and numerous, the waxing and waning of Venus should be visible, and many bright deep-sky objects will fill the eyepiece. Don't expect to see color as you do in NASA photos as our eyes are not sensitive enough to see color in deep-sky objects, except in a few of the brightest ones. Remember that you are seeing these objects using your own eyes, the photons having traveled great distance to register on your eyes and be witnessed by you! Each session with your telescope will be a learning experience. Each time you work with the telescope, it will get easier to use, and stellar objects will become easier to find.

Objects to Observe:

The Moon is one of the easiest and most interesting targets to view with your telescope. Lunar craters, “seas” (relatively flat large dark gray areas filled with ancient lava flows), and even mountain ranges can all be clearly seen from a distance of 238,000 miles away! With its ever-changing phases, you’ll get a new view of the Moon every night it’s up. Make sure to observe the Moon when it is well above the horizon to get the sharpest images. The best time to observe is during a partial phase, that is, when the Moon is *not* full. During partial phases, shadows are cast on the surface, which reveals more detail, especially right along the border between the dark and light portions of the disk (called the “terminator”). Use the Map on the telescope tube to find the major craters and features.

The Planets do not stay at “fixed” locations like the stars do. To find them you should refer to the Sky Calendar (telescope.com), or to charts published monthly in *Astronomy*, *Sky & Telescope*, or Astronomy Magazines and other websites. Venus, Jupiter, and Saturn are the brightest objects in the sky after the Sun and the Moon.

Stars: Even powerful telescopes cannot magnify a star to appear as more than a point of light. You can, however, enjoy the different colors of the stars and locate many pretty double and multiple

stars. (Look at the middle star in the handle of the Big Dipper, Mizar. It is really two stars very close together. Being able to see the two stars separate is called “Star Splitting”. The gorgeous two-color double star, Albireo, in Cygnus is a favorite. Defocusing a star slightly can help bring out its color.

Deep-Sky Objects: Under dark skies, you can see lots of fascinating deep-sky objects, including nebulae, star clusters, and a variety of different types of galaxies.

Most deep-sky objects are very faint, so it is important that you find an observing site well away from light pollution. Take plenty of time to let your eyes adjust to the darkness. Do not expect these subjects to appear like the photographs you see in books and magazines; many will look like dim gray smudges. As you become more experienced and your observing skills get sharper, you will be able to ferret out more and more subtle details and structure.

Deep-Sky objects, also referred to as “dim-fuzzes”, are often hard to find at first but the challenge of finding them is part of the fun. To get the most out of viewing them learn a bit about each one before viewing them. To find deep-sky objects, look up the seasonal sky charts in the National Audubon Society Constellations Pocket Guide (starting on pg. 34). Find your season and a clear direction and match the stars with the chart. After locating a constellation that is high in the sky, turn to pg. 74 and thumb through the alphabetical list of constellations and look for the heading “Deep-Sky Objects” when you find the right page. Many constellations have numerous objects

hidden within them that are only visible with a telescope or binoculars. Pay particular attention to objects with a “Messier Number”, like The Orion Nebula (M-42) and the Andromeda Galaxy (M-31). First published in 1774, Charles Messier made this list to help observers identify objects that might be mistaken for comets. Messier’s list includes some of the brightest and most attractive deep sky objects observable from the northern hemisphere

Star Clusters are particularly pretty, usually bright and easy to see. It is important to know that some Messier Objects are fairly easy to find and others quite difficult. CAAS has a list of the easier “M” objects to find on the website referenced below. A few are very dim, but may seem to appear like magic when you look at them “out of the corner of your eye”. This is called “Averted Vision” and works well when looking at very dim objects. Don’t look straight at it, but slightly to one side.

More information about what to view with your LTP scope can be found at: <http://ltp.caasastro.org/>

Star Hopping: This term describes how one uses a star chart to find objects too dim to see without a telescope. You likely already know how to do this, if you can find the North Star by following the “pointer stars” of the Big Dipper. To find a deep sky object, look for a pattern of stars that can act as landmarks

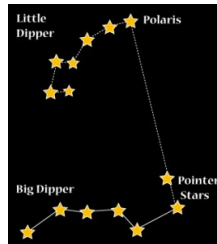

for it. For example: To find the Pinwheel Galaxy, M 101, look for the last two stars of the Big Dippers handle. They make the base of a triangle that has the M 101 at the top.

You can also try a low-power (24 mm) scanning of the Milky Way: just cruise through the “star clouds” of our galaxy. You’ll be amazed at the rich fields of stars and objects you’ll see!

When to go observing:

“Seeing” and Transparency: Atmospheric conditions vary significantly from night to night. “Seeing” refers to the steadiness of the Earth’s atmosphere at a given time. Transparency is just that, how clear the sky is to incoming celestial light.

In conditions of poor seeing, atmospheric turbulence causes objects viewed through the telescope to “boil”. In conditions of good seeing, star twinkling is minimal and images appear steady in the eyepiece. Seeing is always best overhead, worst at the horizon. Seeing is most important for observing the moon and planets. Good “transparency” is especially important for observing faint objects. Transparency is judged by the magnitude of the faintest stars you can see with the unaided eye (Mag. 1 is very bright, 2 is dimmer, and so on... 4th magnitude or fainter is desirable).

Looking at the Little Dipper will show you how good the

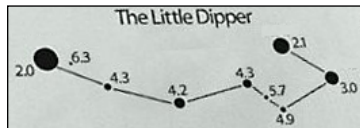

transparency is. If you can see all the stars, you are doing pretty well. Be sure to wait until your eyes adapt to the dark.

One more time, and with Feeling! WARNING: Never look directly at the Sun through your telescope or its finder scope — even for an instant — or permanent eye damage could result. Do not point the telescope at the Sun, as parts will melt! Children should use this telescope only with adult supervision

If you go to <http://www.caasastro.org/>, you will find the “Clear Sky Chart” on the home page. The chart is a time line for weather. If you click on the chart, you will link to a detailed explanation. You will also find links to other charts. Pick the closest one to you for local weather conditions. For example, let’s use the NHAS chart: The first 4 bars are the most important: Is it cloudy? How clear is the sky? What is the “Seeing”, and finally, how dark is it? The deeper blue the squares are, the better. In the chart below, Saturday night looks very good, while Sunday night will be cloudy.

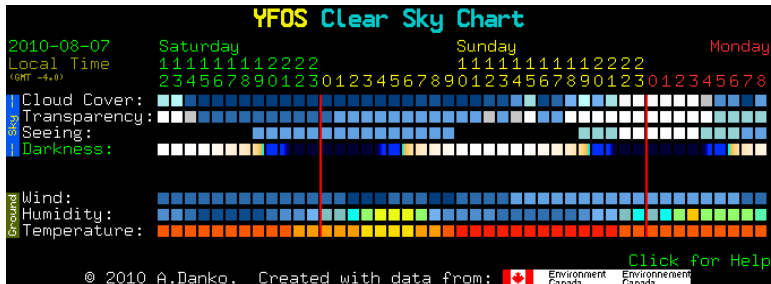

*"The best thing that we're put here for's to see;
The strongest thing that's given us to see with's
a telescope. Someone in every town
seems to me owes it to the town to keep one.
In Littleton it may as well be me."*

*Brad McLaughlin, quoted by Robert Frost
in "The Star Splitter"*

(Please say "thank you" to the librarian for being that person!)